



AL SERVICIO DE LA INDUSTRIA ALIMENTARIA DESDE 1951

## HORNO CON CINTA TRANSPORTADORA DE 14"

Artículo: 11387

Modelo: CE-TW-0356

Diseñado para proporcionar calor constante con calentadores infrarrojos. Equipado con un control de velocidad Variable y controles de calor superiores e inferiores ajustables. El cuerpo está fabricado de atractivo a cero inoxidable. Excelente para pan, bagels y pizzas. Ideal para cocinas grandes, comedores y cafeterías.



LIMITADO

PIEZAS Y MANO DE O BRA

GARANTÍA



Distribuidor a utorizado

# EQUIPO D E ALIMENTOS

HORNO CON CINTA TRANSPORTADORA D E 14"



ESPECIFICACIONES TÉCNICAS	
NÚMERO D E A RTÍCULO	11387
MODELO	CETW0356
Amperios	15 amperios
FUERZA	3.6 kW
ANCHO D E L C INTURÓN	14" / 355 mm
APERTURA (Al x An)	3,3" x 14,3" / 83 x 363 mm
CAPACIDAD	Dieciséis pizzas de 14"/hora
	Diecinueve pizzas de 12"/hora
	Veinticinco pizzas de 9"/hora
ELÉCTRICO	240V /60Hz/1
TEMPERATURA RANGO	70 - 260°C / 158 - 500°F
DIMENSIÓN (DWH)	41" x 18,5" x 15,7" / 1050x470x400mm
PESO	53 libras/24 kg.
PESO BRUTO	61 libras/27,7 kg.
BRUTO DIMENSIONES	36,5" x 26" x 19" / 927x660x482,6mm

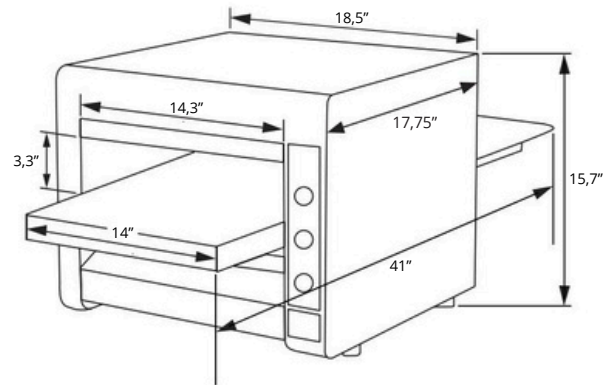

## TIEMPOS DE COCCIÓN RECOMENDADOS

Producto	Calor superior	Calor inferior	Velocidad de la cinta
Pizza de 12" (blanqueada)	300°F/149°C	400°F/204.4°C	6 minutos.
Carne y queso sándwich	450°F/232°C	300°F/149°C	4 minutos.
Albóndiga	500°F/260°C	350°F/177°C	2 minutos.
Bagel (abierto)	500°F/260°C	400°F/204.4°C	2 minutos.
1 onza de galletas	200°F/93°C	250°F/121°C	10 minutos.
Pan de ajo (Ligeramente sazonado)	500°F/260°C	500°F/260°C	2 minutos.
Pescado	400°F/204.4°C	500°F/260°C	6 minutos.

## AJUSTE DE TEMPERATURA Y TIEMPO

Configuración	Temperatura (Calor superior e inferior)	Tiempo (minutos segundos)
Marcar 1	7090 °C/158194 °F	1'20"
Marcar 2	90110 °C/194230 °F	1'45"
Marque 3	130140°C / 266284°F	3'30"
Marque 4	140155 °C/284311 °F	4'20"
Marque 5	155180 °C/311356 °F	5'05"
Marque 6	185205 °C/365401 °F	5'45"
Marque 7	205220 °C/401428 °F	6'35"
Marque 8	240260 °C/464500 °F	7'45"
Marque 9	250260 °C/482500 °F	8'50"
Marque 10	250260 °C/482500 °F	10'05"

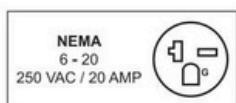

# EQUIPO DE ALIMENTOS

HORNO TRANSPORTADOR CON CINTA TRANSPORTADORA DE 14"



## IMÁGENES DE DETALLE



Cuerpo de acero inoxidable con 18,5" de ancho



Cinta transportadora de horno de acero inoxidable.

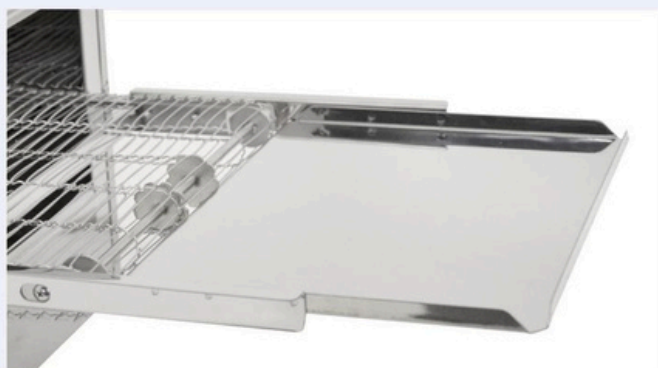

Bandeja desmontable



Longitud del cinturón de 41" (con bandeja desmontable)



Bandeja de goteo extraíble

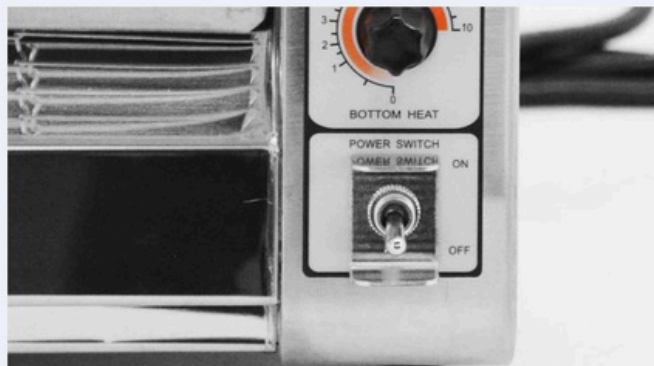

Control de encendido/apagado

